

Section 2

Designing Rubber Components



- Working Together 2-2
- Engineering Design 2-2
 - What will be the function of the part? 2-2
 - What is the environment in which it will function? 2-2
 - How long must it perform correctly? What properties must the part exhibit? ... 2-2
- Cost Effective Custom-Molded Seals 2-2
- Avoiding Rubber Component Design Problems ... 2-2
- Properties in Balance 2-3
- Selecting an Elastomeric Material 2-3
 - Elastomer Hardness Selection 2-3
 - Where to Start 2-4
- Corners and Edges 2-4
- Undercuts 2-5
- Holes 2-5
- Sharp Edges 2-5
- Circularity 2-6
- Total Indicator Reading 2-6
- Rubber Over-Molding 2-6
- Minnesota Rubber and Plastics Standard Tolerance Chart 2-8
- Rubber Molding Considerations 2-9
- Building the Mold 2-9
- Molding Processes 2-10
- Deflashing 2-11
- Gates 2-11
- Feed Examples 2-11
- Building a Prototype 2-12
- Selecting the Mold 2-12
- Parts Assembly and Prototype Testing 2-12
- Specifying Metal Parts 2-12
- CAD Data Interchange Capabilities 2-12
- Writing Your Rubber Component Specifications ... 2-13

Designing Rubber Components

2-2

Working Together

When a designer specifies rubber or plastic for a product or component, it's because no other material can duplicate the required performance characteristics. However, most design engineers do not have the time to become rubber and plastic experts.

The purpose of this Guide is to provide a better understanding of the processes, materials and technical considerations involved in the design and manufacture of custom-molded rubber and plastic parts. By understanding these considerations, you can better control costs while improving the performance of your product.

At Minnesota Rubber and Plastics we specialize in finding solutions to tough applications which require the molding and assembly of close tolerance components. Our capabilities allow us to offer unified technologies to assist in design recommendations and complete project management to accelerate time-to-market.

Engineering Design

Part design begins with answers to some basic questions about how the part will be used and the environment in which it must operate.

What will be the function of the part?

- Seal a fluid? (Impermeable to particular fluid?)
- Transmit a fluid?
- Transmit energy?
- Absorb energy?
- Provide structural support?

What is the environment in which it will function?

- Water, chemicals or solvents that could cause shrinkage of the part?
- Oxygen or ozone?
- Sunlight?
- Wet/dry situation?
- Constant pressure or pressure cycle?
- Dynamic stress, causing potential deformation?

How long must it perform correctly?

What properties must the part exhibit?

- Need to stretch without breaking (high ultimate elongation)?
- Resistance to deformation (high modulus)?
- Resistance to set under extensive load (high compression set)?
- Resistance to dimensional changes or embrittlement in the presence of heat or fluids?

Cost Effective Custom-Molded Seals

Engineers sometimes have the idea that custom parts are cost-prohibitive, so they design their products with less effective standard parts to avoid possible perceived added cost. However, in the long run, a well designed custom molded part can improve product performance, longevity and function, therefore reducing overall costs.

Avoiding Rubber Component Design Problems

The unique aspects of rubber product design require care to prevent unforeseen problems in the performance or manufacture of a part. The following is a list of common problems sometimes encountered when designing rubber parts, and some suggestions for avoiding them.

1. Attempting to compress rubber (or overfilling the groove)
2. Designing a rubber part which cannot be manufactured
3. Not providing installation tools and/or employee training
4. Failing to consider all possible chemicals/processes which may contact the rubber component
5. Not providing sufficient lubrication for a seal or other dynamic rubber part
6. Not allowing enough room for a seal or rubber part
7. Using too small a seal or rubber part
8. Using a seal as a bearing
9. Not considering rubber thermal effects
10. Not accounting for seal friction and power loss

Properties in Balance

Choosing the correct material always involves tradeoffs in performance, as illustrated in the following chart. The key then is to determine and prioritize your part's most critical performance characteristics.

| An improvement in... | Usually improves... | But sacrifices... |
|----------------------|---------------------|----------------------|
| Abrasion resistance | Hardness/Elongation | Resilience |
| Impact resistance | Elongation | Modulus |
| Creep resistance | Resilience | Flex resistance |
| Oil resistance | Tear resistance | Low temperature flex |
| Resilience | Creep resistance | Tear resistance |
| Tensile strength | Modulus | Elongation |
| Vibration damping | Impact resistance | Structural integrity |

Selecting an Elastomeric Material

One of the most important aspects of designing a sealing system, or any other elastomeric component, is making a proper material selection. There are many different elastomeric materials from which to choose, and selecting the "best" material means balancing suitability for the application, performance, cost, and ease of manufacturing. Minnesota Rubber and Plastics manufactures and uses hundreds of different types of elastomeric materials. Contact us for assistance in selecting a material for your application.

1. How and where will the part actually be used? How will it be stored and transported? What will it be located next to?
2. What is the environment in which the seal or part is operating, including fluids, gases, contaminants, pressures, temperatures, etc.?
3. What are your performance objectives for the part, including life span and duty cycle?
4. What is your product worth in the marketplace, and are your performance objectives achievable at the market price?

When selecting a material for your application, consider the following:

- The primary fluid(s) to which the elastomer will be exposed.
- Secondary fluids to which the elastomer will be exposed, such as cleaning fluids or lubricants.

- Exposure to chloramines in water.
- The suitability of the material for the application's temperature extremes, both hot and cold.
- The presence of abrasive external contaminants.
- The presence of ozone from natural and artificial sources, such as electric motors, which can attack rubber.
- Exposure to processes such as sterilization by gas, autoclaving, or radiation.
- Exposure to ultraviolet light and sunlight, which can decompose rubber.
- The potential for outgassing in vacuum applications.
- Will the product come in contact with the human body, directly or indirectly, and if so, for how long a period?
- Does your part need to be a special or specific color?

Elastomer Hardness Selection

Elastomeric materials are available in a wide variety of hardnesses, from 20 Shore A to 90 Shore A for thermoset rubbers, to even harder materials (Shore D scale) for thermoplastic elastomers. The most common hardness range for materials is from 50 Shore A to 80 Shore A, with most sealing products being made from materials with a hardness of 70 Shore A. The actual hardness which will be selected depends upon your exact application.

There are some restrictions on the use of very hard and very

soft materials in terms of manufacturing limitations. Parts with complex geometry or deep undercuts can be difficult to manufacture from very soft (< 30 Shore A) or very hard (> 80 Shore A) materials.

| Application Type | Hardness Range (Shore A) |
|--|--------------------------|
| Sealing Applications (depending on pressure) | 60 - 80 |
| Flow Controllers | 50 - 70 |
| Umbrella/Duckbill Check Valves | 50 - 60 |

Where to Start

Here are a few suggestions for beginning the process of material selection:

- If you are selecting a material for an O-Ring or Quad-Ring®, consider one of the two standard, "off-the-shelf" Minnesota Rubber and Plastics materials, 366Y, (a 70 Shore A nitrile rubber,) or 514AD, (a 70 Shore A fluoroelastomer rubber.) These are suitable for many industrial applications and are readily available.
- Nitrile rubber is a good general purpose rubber.
- If you are designing a potable water application, consider the use of an EP rubber, as long as the rubber will not come in contact with hydrocarbon based oils and greases, which will cause it to swell and degrade.
- If you are designing a medical application involving human contact or high cleanliness requirements, consider the use of a silicone rubber.
- If your application will experience temperatures greater than 300° F (150° C) in an industrial environment, a fluoroelastomer may be a good choice.

Corners and Edges

When designing rubber parts, sharp corners are generally undesirable. A part's corners should be broken with as gentle a radius as possible, preferably one greater than .050 inches, although radii as small as .010 inches are possible. A sharp corner increases the difficulty (and therefore the cost) of machining the mold and can potentially affect product quality by increasing the likelihood of certain types of mold-ed defects.

It is preferred that a part's edges, where they coincide with a parting line, should be sharp. This simplifies the mold construction. Radii, when necessary or desired, however, can usually be added by relocating the part line.

The preferred methods for designing corners and edges are illustrated in the following figures:

Corners: When viewed from the top, the part should display round corners.

Edges: When seen from the side, the edges should be square.

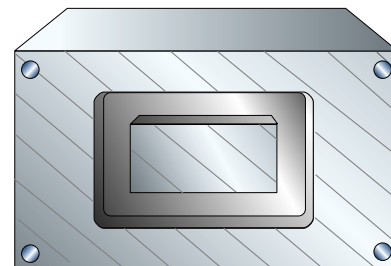

Correct

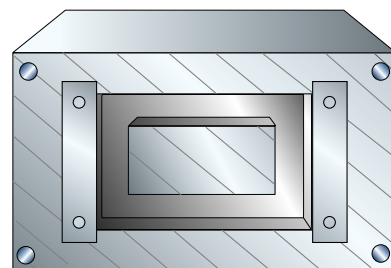

Incorrect

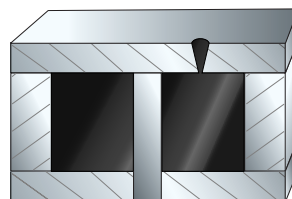

Preferred

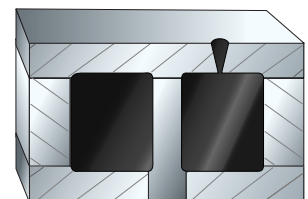

Least Preferred

Undercuts

An undercut feature of a part is one which projects back into the main body of the part. As the undercut becomes deeper, it results in a part that is difficult, or perhaps impossible, to remove from the mold. An extreme case of an undercut part is illustrated here, with the cross-section of a part in a mold. The mold, composed of three sections, opens vertically. In this example, it would not be possible to remove the part from the vertically opening mold.



When an undercut feature is essential to the functionality of a part, it may be possible to design a mold that opens horizontally as well as vertically, as shown in the following illustration. When removing the part from this mold, the center plate separates and the part slides out, much easier than trying to pull the undercut feature through the center hole. These types of molds, however, are very costly to construct and operate and result in a relatively high part cost.

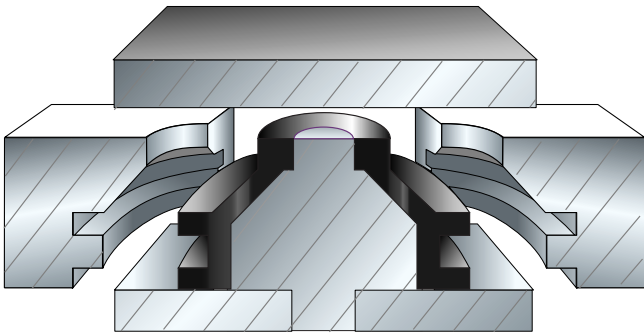

Holes

When designing a hole in a rubber part, there are a few design requirements to consider. The hole in the part is created by inserting a pin in the mold cavity. During molding, cavity pressures can be quite high (in excess of 7000 psi (500 Bar)), so substantial forces can be exerted on the pin,

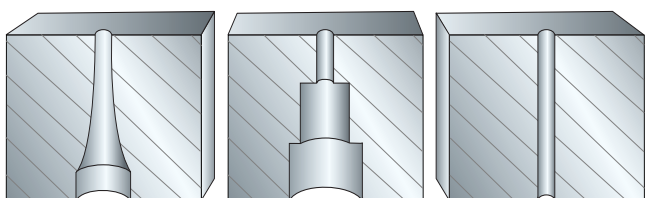

Preferred

Alternate

Least Preferred

potentially deflecting it and creating an inconsistent hole. The size of the core pin, and thus the diameter of the hole, should therefore be maximized whenever possible, particularly at the base, to prevent bending or breaking of the core pin. A couple of useful "rules of thumb" to remember are:

- The height of the hole should not be more than twice its diameter.
- The minimum diameter of a hole should be about .050 in (1.27 mm).

Sharp Edges

Wiper seals, lip seals, and similar parts are frequently designed with a sharp edge, referred to as a knife edge or feather edge. It is difficult to hold such a thin edge in the molding process, as these edges tend to tear during removal from the mold. Normal deflashing can also chip a sharp edge.

Unless a sharp edge is absolutely necessary, we recommend squaring off edges [.010 in (0.25 mm) minimum flat] to ensure clean surfaces on the finished product.

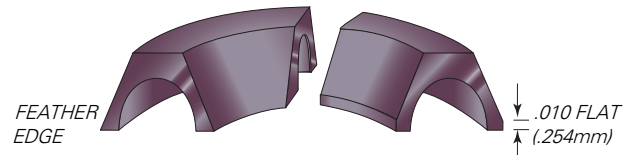
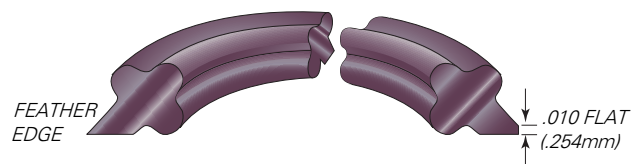
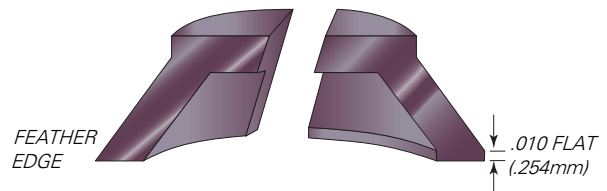
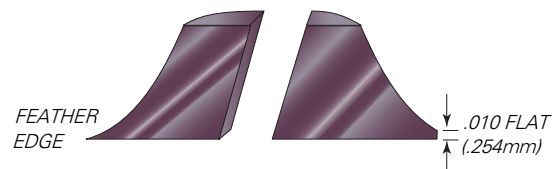

Circularity

A rubber ball provides an effective and efficient seal in check valve type applications. The ball's effectiveness in sealing, however, is dependent on its roundness. Circularity tolerances normally range from .006-.008 (0.15 - 0.20 mm) for molded-only parts.

Parts with diameters of .093 - 1.000 (2.36 - 25.40 mm) can be put through a centerless grinder to remove gates and parting lines, reducing the variation to .003-.004 (0.08 - 0.10 mm).



Correct

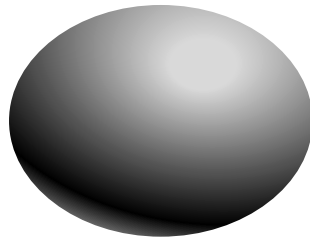

Incorrect

Total Indicator Reading

Total Indicator Reading (TIR) measures roundness in relationship to a center line. TIR is expressed in total diametric deviation. Example: +/- .004 (0.10mm) deviation is defined as .008 (0.20mm) TIR.

TIR is the total lateral distance traveled by the indicator needle resting against the O.D. of a round part as the part is turned one full revolution.

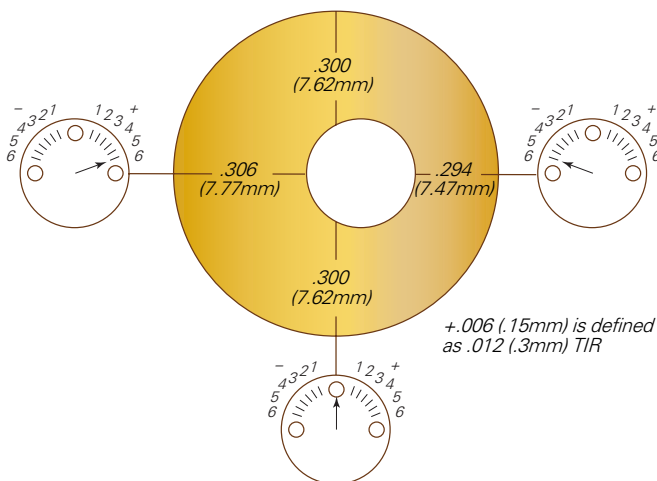

Rubber Over-Molding

Steel, brass, aluminum, or plastic subcomponents are often incorporated into overmolded rubber parts. These subcomponents are commonly termed inserts, as they are "inserted into the mold." Typical metal inserts include screw machine parts, metal stampings, and powdered metal shapes.

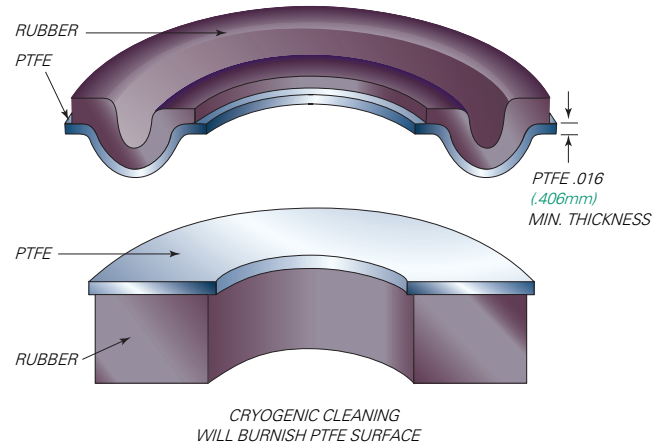

When designing rubber overmolded parts, keep in mind the following design principles:

1. Encapsulate as much of the surface of the insert in rubber as possible, with a minimum specified rubber thickness of .020 in (0.51 mm). This coverage helps to ensure maximum bonding and control flash formation.
2. Avoid shutting rubber flow off on vertical surfaces and provide proper lands (steps).
3. The rubber can be molded to the insert by means of mechanical or chemical bonding. Mechanical bonding involves the incorporation of holes, depressions or projections in the insert itself. The rubber flows around or through the insert during the molding process to create a bond.

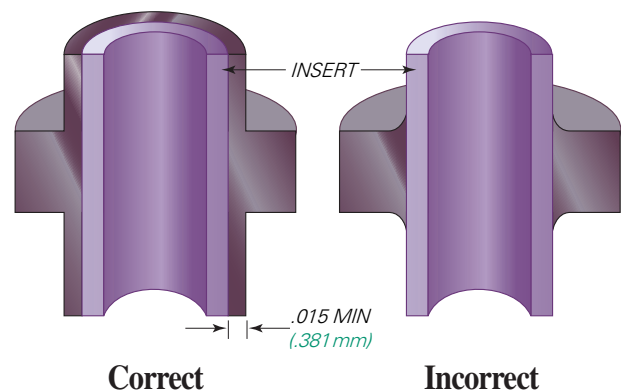

Special adhesives can be applied to the insert prior to molding to create a strong chemical bond.

Inserts designed for use in demanding applications are often attached to the rubber part using a combination of mechanical and chemical bonding.

The production of molded rubber parts containing inserts typically involves considerable preparation before and after molding. Steps may include cleaning and etching of the insert surfaces, masking and unmasking, application of adhesives, and deflashing. Careful design of the insert can help to ensure a durable finished part while minimizing production costs.

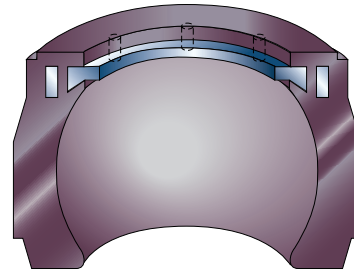

Mechanical Bond

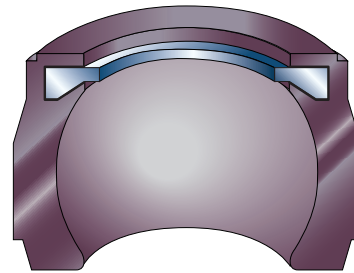

Chemical Bond

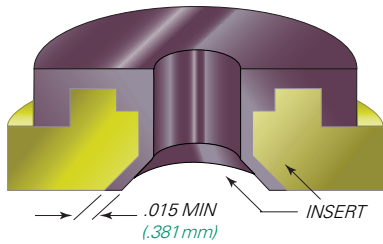

Correct

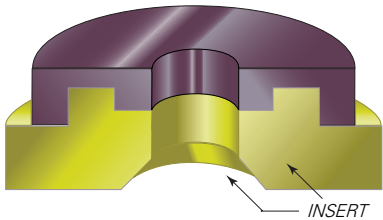

Incorrect

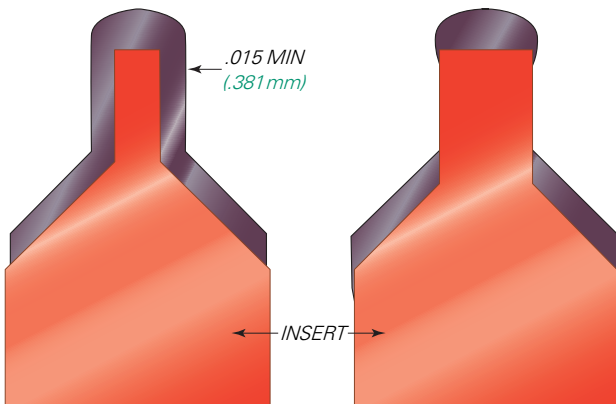

Correct

Incorrect

Minnesota Rubber and Plastics Standard Tolerance Chart

The following tolerance information is for reference purposes only and is intended to provide an indication of the types of tolerances which can be achieved with a molded part. This chart does not represent a guarantee of the tolerances which can be achieved in all cases. In many

instances, specific part geometry will affect the precision of the tolerances which can be achieved. Please contact our Customer Service Group if you need a tolerance assessment conducted for a specific product.

Recommended Tolerances

| Dimension | | Fixed Dimension Tolerance | | Closure Dimension Tolerance | |
|-----------------|-------------------|---------------------------|--------|-----------------------------|--------|
| (in) | (mm) | (in) | (mm) | (in) | (mm) |
| .001 - .250 | .0254 - 6.350 | ±.004 | ±.102 | ±.005 | ±.127 |
| .251 - .500 | 6.375 - 12.700 | ±.004 | ±.102 | ±.005 | ±.127 |
| .501 - .625 | 12.725 - 15.875 | ±.005 | ±.127 | ±.006 | ±.152 |
| .626 - .750 | 15.900 - 19.050 | ±.006 | ±.152 | ±.008 | ±.203 |
| .751 - 1.000 | 19.075 - 25.400 | ±.006 | ±.152 | ±.008 | ±.203 |
| 1.001 - 1.500 | 25.425 - 38.100 | ±.008 | ±.203 | ±.010 | ±.254 |
| 1.501 - 2.000 | 38.125 - 50.800 | ±.010 | ±.254 | ±.013 | ±.330 |
| 2.001 - 2.500 | 50.825 - 63.500 | ±.010 | ±.254 | ±.013 | ±.330 |
| 2.501 - 3.000 | 63.525 - 76.200 | ±.014 | ±.355 | ±.015 | ±.381 |
| 3.001 - 3.500 | 76.225 - 88.900 | ±.017 | ±.432 | ±.018 | ±.457 |
| 3.501 - 4.000 | 88.925 - 101.600 | ±.020 | ±.508 | ±.020 | ±.508 |
| 4.001 - 5.000 | 101.625 - 127.000 | ±.025 | ±.635 | ±.025 | ±.635 |
| 5.001 - 7.000 | 127.025 - 177.800 | ±.035 | ±.890 | ±.035 | ±.890 |
| 7.001 - 8.000 | 177.825 - 203.200 | ±.040 | ±1.016 | ±.040 | ±1.016 |
| 8.001 - 9.000 | 203.225 - 228.600 | ±.045 | ±1.143 | ±.045 | ±1.143 |
| 9.001 - 10.000 | 228.625 - 254.000 | ±.050 | ±1.270 | ±.050 | ±1.270 |
| 10.001 - 11.000 | 254.025 - 279.400 | ±.055 | ±1.397 | ±.055 | ±1.397 |
| 11.001 - 13.000 | 279.425 - 330.200 | ±.065 | ±1.651 | ±.065 | ±1.651 |
| 13.001 - 14.000 | 330.225 - 355.600 | ±.075 | ±1.905 | ±.075 | ±1.905 |
| 14.001 - 15.000 | 355.625 - 381.000 | ±.090 | ±2.286 | ±.090 | ±2.286 |

Rubber Molding Considerations

The manufacturing of rubber parts is accomplished in one of three ways: transfer molding, compression molding or injection molding. (Each is described later in more detail.) The choice of process depends on a number of factors, including the size, shape and function of the part, anticipated quantity, type and cost of the raw material. The three methods, however, share certain basic characteristics that are important to understand when designing custom molded rubber parts.

Building the Mold

The custom molding process begins with design and construction of a precision machined steel mold. This mold, or tool, consists of two or more custom tooled steel plates carefully registered to ensure consistent close tolerances and appropriate surface finish. After the rubber compound is placed or injected in the mold, the plates are exposed to heat and pressure to cure the part. The exact mix of time, temperature and pressure depends on the molding process and material.

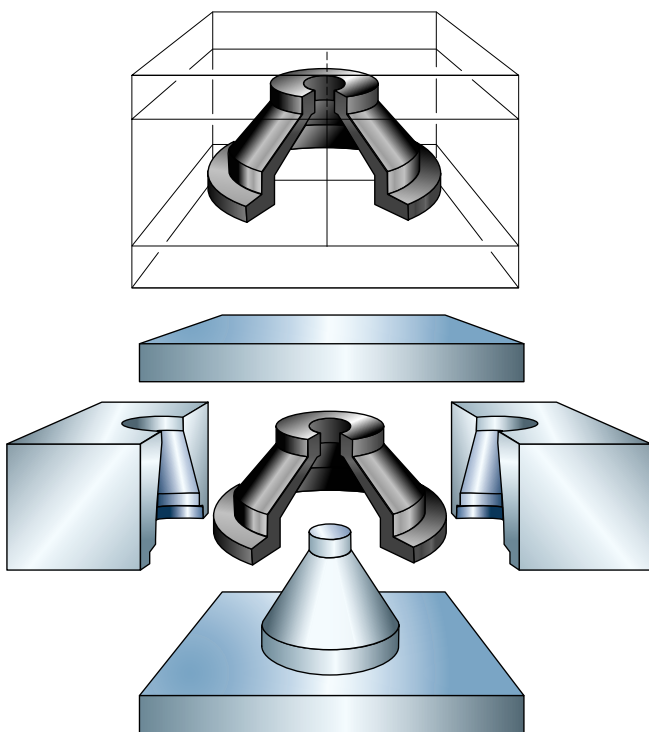

NOTE: Rubber is a thermoset material; once the rubber has been cured, it cannot be remolded. The curing process is irreversible.

A molded rubber part, such as the simple rubber bushing shown, begins in the designers mind as a cavity in a solid steel block.

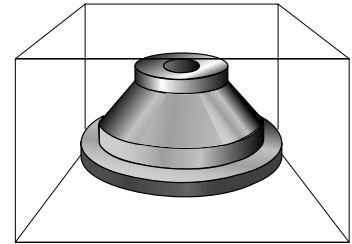

In order to get at the part, the block is “sliced” into plates. A tool steel pin called a core pin is inserted into one of the plates to form the interior dimensions of the part. The line on the surface of the part where the plates meet is the parting line.

An excess amount of rubber is necessary in the cavity to ensure complete cavity fill and proper density. When pressure is applied, a small amount of this material is forced out of the cavity along the parting line to form a thin ridge of material known as flash. Removal of this flash from the part (deflashing), is accomplished in a number of different ways, described on page 2-11 and 7-3.

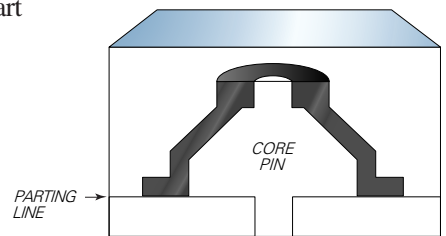

Sometimes the presence of a parting line is objectionable to the designer for functional or aesthetic reasons. This condition can be prevented by shifting the parting line from the top or bottom to the middle of the part.

A molded part may be too delicate, too small or too firm to be removed by hand from the cavity of a two-plate mold. Depending on the viscosity of the raw rubber, air may be trapped under the material, resulting in air pockets or weak sections in the finished part.

A common solution to both of these problems is a three-plate mold, as shown. When the molding process is complete, the plates are separated and the part is pushed out by hand or blown out with air.

A common solution to both of these problems is a three-plate mold, as shown. When the molding process is complete, the plates are separated and the part is pushed out by hand or blown out with air.

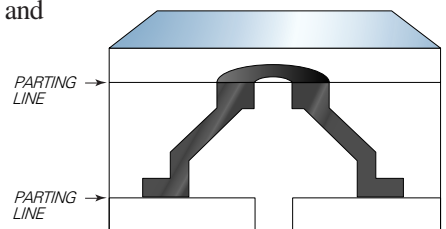
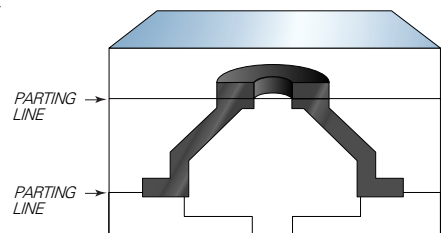

Molding Processes

Minnesota Rubber and Plastics' custom-molding capabilities encompass all three processes – transfer, compression and injection molding. We select from among these methods based on a number of key factors, including: the size and shape of the part, the hardness, flow and cost of the material, and the anticipated number of parts to be produced.

Compression Molding

The compression molding process is not unlike making a waffle. A surplus of material must be placed in the cavity to ensure total cavity fill. Heat and pressure are applied, causing the compound to flow, filling the cavity and spilling out into overflow grooves.

Compression molding is often chosen for medium hardness compounds – in high volume production, or applications requiring particularly expensive materials.

The overflow, or flash, created by larger diameter parts is of particular concern when using the more expensive compounds. Compression molding helps to minimize the amount of overflow. The pre-load, however, can be difficult to insert in a compression mold of more complex design, and the compression molding process does not lend itself to the material flow requirement of harder rubber compounds.

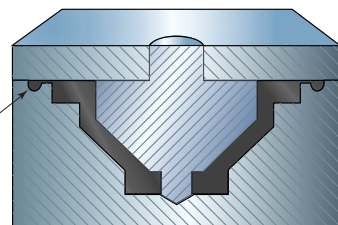
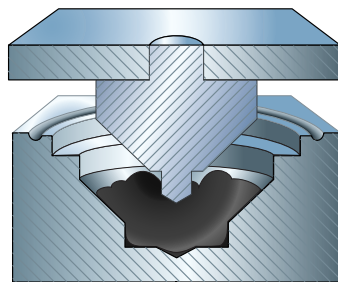
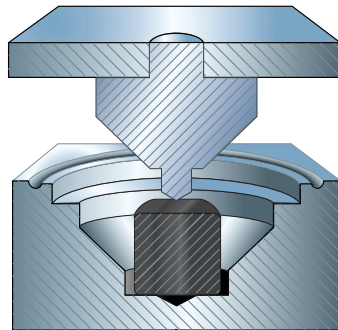

Applications range from simple o-ring drive belts to complex brake diaphragms with diameter of more than 10.000 inches (254.0mm).

Transfer Molding

Transfer molding differs from compression molding in that the material is placed in a pot, located between the top plate and plunger. The material is squeezed from the pot into the cavity through one or more orifices called gates, or sprues.

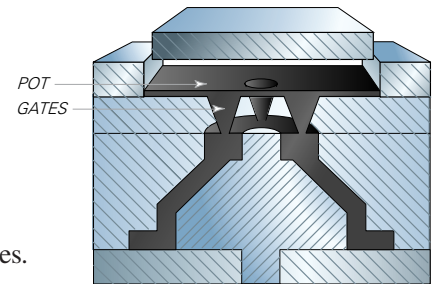

Injection Molding

Injection molding is normally the most automated of the molding processes. The material is heated to a flowing state and injected under pressure from the heating chamber through a series of runners or sprues into the mold. Injection molding is ideal for the high volume production of molded rubber parts of relatively simple configuration.

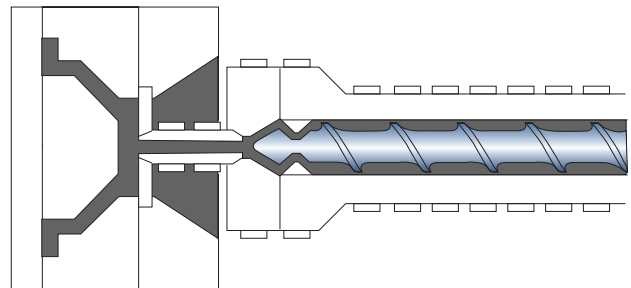

NOTE: There are some restrictions in the choice of material for injection molding.

Deflashing

Removal of the waste edge, or flash, from a molded rubber part is accomplished in a number of ways, depending on the material, part size, tolerance and quantity. Common deflashing methods include manual tear trimming, cryogenic processing, tumbling, and precision grinding.

Gates

Transfer and injection molds typically feature multiple gates to ensure even flow of the material into the cavity. These gates range in diameter from .010 - .150 (.254 – 3.81mm), placed at intervals along the circumference of the cavity. Gate diameter and location are determined by our Engineering Department in conjunction with the customer so as not to hinder part function.

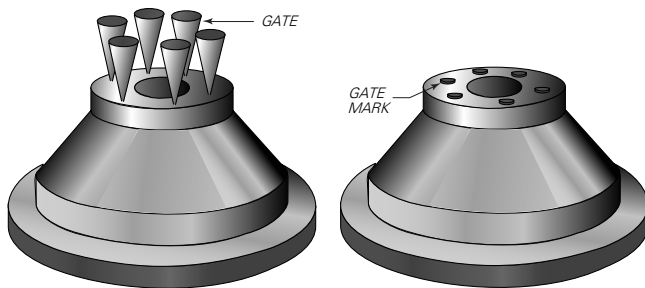

A raised spot or small depression, called a gate mark or sprue mark, can be seen on the surface of the finished part where the gates interface with the cavity.

| Material Durometer | Typical depression or projection from surface of part |
|--------------------|---|
| less than 50 | .015 (.381 mm) |
| 50 or more | .007 (.178 mm) |

Feed Examples

The number, size and location of gates in even the simplest mold design can vary greatly depending on the molding process, hardness of the material, dimensional tolerances, cosmetic consideration, and other customer requirements or specifications.

Illustrated here are 5 of the most common mold configurations:

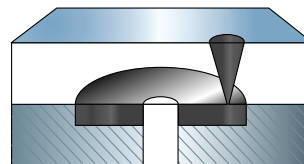
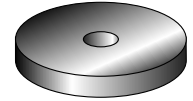

Body Feed

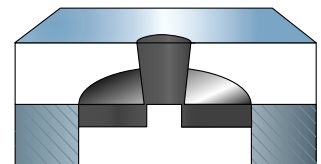

Flush Pin Feed

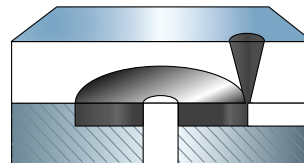

Edge Feed

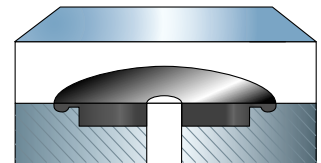

Compression

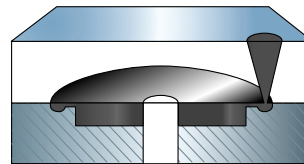

Parting Line Feed

Building a Prototype

The building and testing of prototype parts allow for detailed analysis of the part design and material selection. What's more, these parts can be tested under actual operating conditions before committing to production. In many cases, this involves the molding of the same part from several different materials, each one chosen for its ability to perform within a specific operating environment.

The endless combination of variables related to part function and production requirements makes every new part a unique challenge. The prototyping process also provides us the opportunity to learn the critical features of your part so that we can recommend the right combination of materials, mold design and production procedures.

We understand that your R&D projects typically run on a very tight schedule, so we make every effort to expedite the prototype-building process and respond quickly to your prototyping needs.

In the end you will receive molded articles produced to your specifications, identical in material and dimensional tolerances to those you would receive in normal volume production. All before committing to a production tool.

Selecting the Mold

The recommended mold configuration and molding process depend on the size and complexity of the part, anticipated production volumes, type(s) of material involved, part function, and quantity requirements.

The key is to select the mold design and process that most closely approximates actual production conditions and cost requirements. The more demanding the part design, the more critical it becomes that we build the prototype cavity just as we would a production cavity. The upfront investment in a more costly mold may pay for itself very quickly through lower material costs or more improved handling procedures.

A two-part, single-cavity mold is typical for prototype quantities of up to 200 pieces, though two-to nine-cavity molds are not uncommon. The real advantage of a single-cavity mold is that it lets you change part design or material at minimal cost before committing to production.

For more information on mold design and process selection, see page 2-10, "The Molding Process."

Parts Assembly and Prototype Testing

In some cases, instead of building a single, complex mold, we may recommend the use of several parts of simpler configuration which can be molded and assembled to produce the finished prototype.

In order to reduce costs or improve lead times on plastic parts, we may begin with a standard shape and modify it to specification using various machining techniques such as drilling, turning, and/or milling.

Specifying Metal Parts

Based on our experience in both rubber and plastics molding and metals purchasing, we can specify and purchase for you any metal parts required for assembly of your prototype and production parts.

CAD Data Interchange Capabilities

Native CAD File Formats

We maintain current versions (and often previous versions) of the following CAD applications.

- EDS (SDRC) I-DEAS®*
- Unigraphics®
- ProEngineer®
- AutoCAD LT®
- SolidWorks®

* Preferred CAD system

Standardized File Formats

We also maintain the capability to view and import the following standardized file formats

- 3-D IGES
- VRML
- STEP
- DXF
- HPGL
- VDA
- STL
- PDF
- DWG

Email is the preferred method of delivery, but any contemporary media may be used. Files may be sent to your usual contact at Minnesota Rubber and Plastics.

Writing Your Rubber Component Specifications

(For plastic components, see our "Writing Your Plastic Component Specifications" in Section 4.)

Contact: _____ **Date:** _____

Company name: _____ **Phone:** _____ **Fax:** _____

Address: _____ **e-mail:** _____

Part name: _____ **Part number/Rev.:** _____

Basic description and function of part in application: _____

Elastomer type requested: _____ **Hardness/Durometer:** _____

- Material Specifications (A) _____ (B) _____
- Maximum swell and/or shrinkage permitted _____

Media to be sealed: _____ (Both sides of seal) _____

- Specification _____ ■ Viscosity _____
- Concentration _____ % ■ Aniline point _____
- Continual immersion or subject to dry out _____

Application: (A) Static _____ (B) Dynamic _____

Temperature limit: (A) High _____ (B) Low _____ (C) Normal operation _____

- Continuous _____ ■ Intermittent _____

Pressure or vacuum conditions: Normal operation _____ PSI

- Maximum _____ PSI ■ Minimum _____ PSI
- Constant pressure _____ ■ Pulsating pressure _____
- Unidirectional _____ ■ Bidirectional _____

Shaft motion: • Continuous _____ ■ Intermittent _____

- Rotating _____ ■ Reciprocating _____ ■ Oscillating _____
- RPM/FPM _____ ■ Stroke length _____ ■ Degree _____

Finish of sealing surface: _____ micro inch RMS

- Material _____ ■ Hardness _____

Operating clearances: Maximum _____ total Minimum _____ total

- Bore eccentricity, shaft runout, TIR (Total Indicator Reading) _____

Friction tolerance: Breakaway _____ Running _____

continued on reverse

Lubrication of seal: By fluid sealed _____ External _____ None _____

Life expectancy of seal: _____ Leakage tolerance _____

Visual/Functional Attributes:

- Esthetic value of part _____ If yes, what area _____
- Where and how much parting line flash can be tolerated? _____
- Where and how much gate extension or depression can be tolerated? _____
- Is surface finish critical? _____ Better than 32 micro? _____
- If so, what area? _____
- Critical sealing surfaces _____
- Critical dimensions _____
- Engraving of part _____

Quality Related:

- Anticipated AQL _____
- Cleanliness factor _____
- Special controls: Batch control _____ Lot control _____
- Special packaging _____
- SPC requirements _____
- FDA _____
- UL _____
- NSF _____
- Medical _____

Business Related Criteria:

- Number of prototype samples needed _____ Date needed by _____
- Number of production parts needed _____ Date needed by _____
- Target price _____
- Estimated Annual Usage (EAU) _____

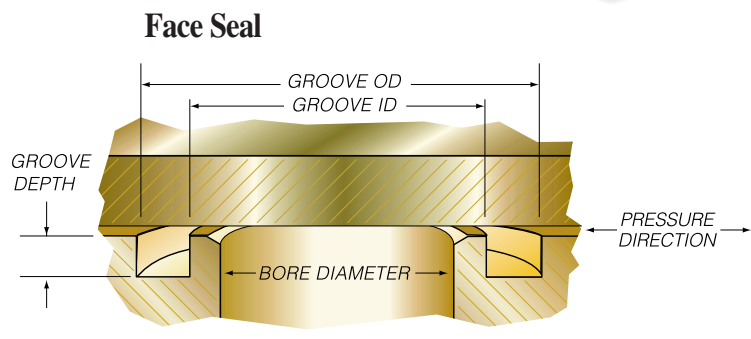
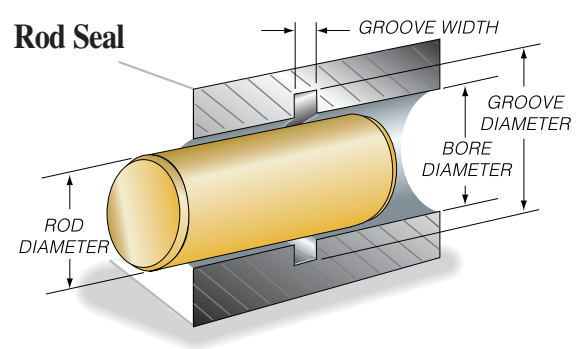
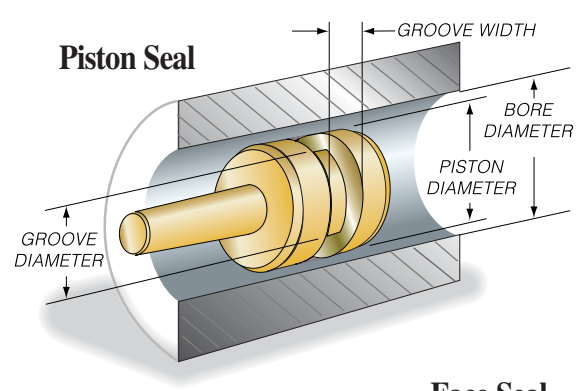

Additional comments or sketch: Make a sketch or attach a print showing the seal area, clamp area, etc., or any of the above which may be easier to illustrate than to describe.